

## Rubber-metal element - Type GMS-1, GMS-2

Rail element, flush outside or with laterally protruding base rail



### Structure type GMS-1 / GMS-2

- Type GMS-1 with metal rails on both sides
- Type GMS-2 with metal rails on both sides, protruding on one side
- Drilled mounting holes can be applied to the metal rails, on-site

### Metal parts

- Material: 1.0038 (S235JR)
- Corrosion protection: oiled or electrogalvanized

### Rubber element

- Rail-shaped rubber element with metal rails as per DIN 1017, vulcanized onto both sides

Rubber grade	Rubber hardness	Possible uses
NBR	medium – 60 Shore A	Water, gas, fuel oil, mineral oil

### Dimensions/stress type GMS-1

B mm	H mm	h mm	s mm	Length max. L mm	Compressive stress Spring rate ref. to L = 100 mm $C_z$ N/mm	Art. No.
20	30	20	5	500	670	51888100-00
25	30	20	5	500	920	51888200-00
40	35	19	8	500	2340	51888300-00
50	40	20	10	2000	3500	51888000-00
50	50	30	10	2000	1500	51887300-00
60	60	40	10	2000	1170	51887500-00
70	50	30	10	2000	2840	51887600-00
100	60	30	15	2000	5400	51887800-00
100	80	50	15	2000	2000	51887900-00
150	65	35	15	2000	7750	51874600-00
150	80	50	15	2000	4170	51874700-00

### Dimensions/stress type GMS-2

B mm	H mm	h mm	S <sub>1</sub> mm	S <sub>2</sub> mm	L mm	L <sub>1</sub> mm	Compressive stress Spring rate $C_z$ N/mm	Load $F_{tol}$ * KN	Art. No.
50	40	20	12	8	200	150	4000	8	51899400-00
50	40	20	12	8	270	220	7100	15	51899500-00
100	60	30	15	15	480	360	18200	59	51899600-00

\*  $F_{tol}$  is the tolerable static permanent load: a dynamic alternating load can be superimposed. The stated tolerable loads are only approximate indications for the static load.

### Applications

- for extremely elastic bearing of heavy machines, e.g.
  - ship's engines
  - large stationary motors
  - lathes and milling machines
  - elevator motors
  - jolters and vibration machines
- for high loads
- for limited space
- for compressive stress
- for superimposed compressive/shearing stress
- for damping sound and vibration

### Versions

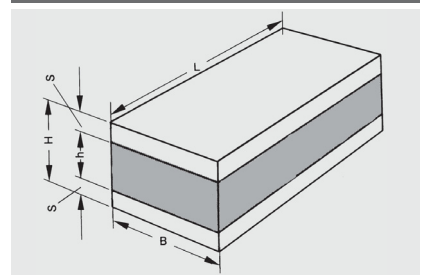

Type GMS-1

Screwable rubber-metal rail element

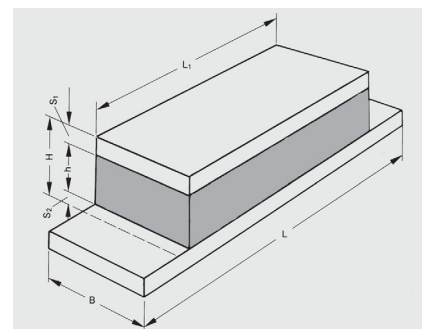

Type GMS-2

Screwable rubber-metal rail element - with protruding base rail at both ends

### Note

Rails with protruding base plate can be compressed under static load by approx. 10 % – 15 % of the rubber height h.

Please comply with general technical instructions. Subject to technical alterations and deviations resulting from the manufacturing process.