

Rubber-metal element - Type GMA-3

Stopper buffer, parabolic cross section



Structure type GMA-3

- Stopper buffer with parabolic cross section and threaded bolt (male thread)

Metal parts

- Material: 1.0038 (S235JR) / 8.8
- Corrosion protection: oiled or electrogalvanized

Rubber element

- Parabolic rubber element with metal plate vulcanized onto one side

Rubber grade	Rubber hardness	Possible uses
NBR	medium – 60 Shore A	Water, gas, fuel oil, mineral oil

Dimensions/stress

ø D mm	H mm	G mm	I mm	Rubber hardness Shore A	Compressive stress Spring excursion max. mm	Load F_{tol}^* N	Art. No.	Pck. qty.
50	61	M 8	26	60	22	2500	51842300-00	10
50	67	M 8	36	60	25	1900	51842200-00	10
95	83	M 16	47	60	30	5000	51842100-00	10

* F_{tol} is the **tolerable static permanent load**: a dynamic alternating load can be superimposed.
The stated tolerable loads are only approximate indications for the static load.
Delivery only possible in the stated packaging quantities (far-right column).

Applications

- as shock buffer stopper
- to limit vibration deflection and spring excursion
- for soft absorption of impacts with progressive curves
- for damping sound and vibration
- for compressive stress
- for superimposed compressive/shearing stress

Version

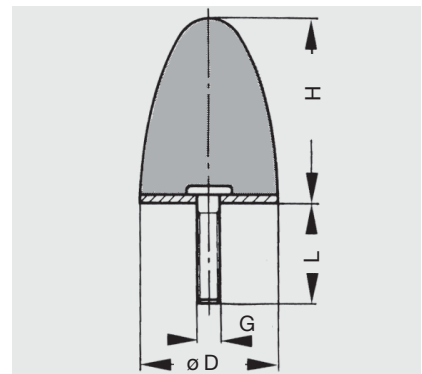

Type GMA-3
One side with male thread

Note

Please comply with general technical instructions. Subject to technical alterations and deviations resulting from the manufacturing process.