

Rubber expansion joint with PTFE lining Type Ai-1

Universal expansion joint DN 32 - DN 500



Structure type Ai-1

Universal expansion joint consisting of a rubber bellows with seamless PTFE lining and rotatable flanges

Applications

- for conveying aggressive media
 - very good chemical resistance
 - resistant to most of the acids and lyes
- for compensating axial, lateral and angular movement
- for muffling vibration and noise
- for reducing thermal and mechanical tension
- to compensate for installation inaccuracies
- chemical industry
- beverage industry

Rubber bellows with PTFE lining PN 10

- Flat-convoluted molded bellows made of EPDM
- Synthetic fibre reinforcement
- Wire-reinforced rubber rim
- Seamless PTFE lining with self-sealing flared ends

Accessories

- Internal guide sleeve of PTFE
- Protective cover

Certificates

- CE (DGR 97/23/EC)

Material grade*	Colour code	Possible uses
EPDM/PTFE	orange with stamp "PTFE-Inliner"	Chemicals, acids, lyes

*Check or inquire about the resistance of the rubber grade to temperature and medium

Technical calculation	Pressure
Max. perm. operating pressure	10 bar*
Max. permissible temperature	+100 °C
Bursting pressure	≥ 20 bar
Vacuum operation	not suitable

Max. operating pressure to be set 30 % lower for shock loads.

*Temperature related decrease of pressure (see technical annex).

Flanges

Version

- Rotable flanges with stabilizing collar
- Flange drilling for through bolts
- Special turned groove for rubber rim

Dimensions

Standard: DN 32 - DN 175 (PN 16)
DN 200 - DN 500 (PN 10)
according to EN 1092

Others: DIN EN, ANSI, BS etc.

Connection dimensions see technical annex

Materials

Standard: 1.0038 (S235JR)

Others: 1.4541, 1.4571,
plastic (PP)

Corrosion protection

Standard: DN 32 - DN 150

electrogalvanized

DN 175 - DN 500

anti-corrosion primed

Others: hot-dip galvanized, special varnish, special coating, etc.

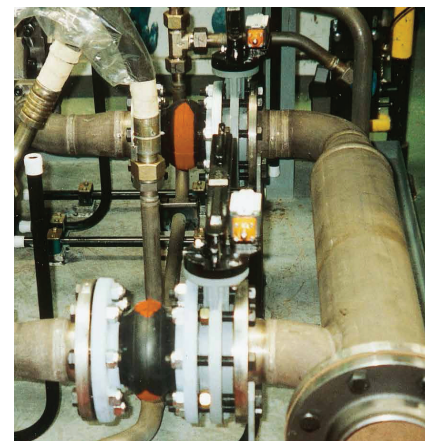

STENFLEX® type Ai-1 with PTFE lining used in the chemical industry

Dimensions standard program

DN	BL*	Pressure rate bar	ø di** Bellows inner ø	ø C Raised face ø	ø W Convolution ø unpressurized	PN Flange connection EN 1092	ø D Flange outer ø	b Flange thickness
	mm		mm	mm	mm		mm	mm
32	131	10	25	82	78	16	140	16
40	131	10	33	92	86	16	150	16
50	131	10	43	101.5	97	16	165	16
65	131	10	59	127	113	16	185	18
80	156	10	71	133	135	16	200	20
100	156	10	94	171.5	160	16	220	20
125	156	10	121	192	184	16	250	22
150	157	10	146	218	212	16	285	22
175	157	10	169	248	236	16	315	22
200	182	10	195	273	265	10	340	25
250	182	10	245	328	318	10	395	25
300	207	10	296	378	373	10	445	25
350	212	10	332	438	420	10	505	30
400	212	10	384	489	460	10	565	30
450	262	10	423	539	575	10	615	35
500	262	10	473	594	625	10	670	35

*DN 32 - DN 125 also available as type Ri-1, length 136, DN 150 - DN 300 also available length 137.
**For manufacturing reasons the inner diameter may vary by ± 3 or ± 5 mm

Versions

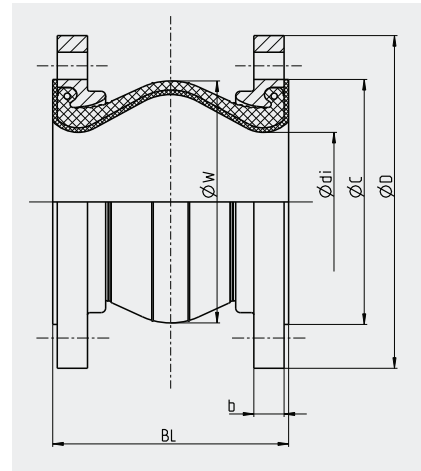

Type Ai-1
Universal expansion joint with PTFE lining and PTFE supporting ring

Movement compensation/bellows cross sectional area

DN	Δ ax Axial movement		Δ lat Lateral movement ± mm	Δ ang Angular movement ± ∠ degrees	A* Effective bellows cross sectional area at 10 bar cm ²	Weight approx. kg
	Compression - mm	Elongation + mm				
32	18	5	8	13	0	3.4
40	18	5	8	13	0	3.9
50	18	5	8	11	0	4.6
65	18	5	8	9	10	5.8
80	18	5	8	7	20	7.5
100	18	5	8	6	40	8.4
125	18	5	8	5	50	11.1
150	18	5	8	4	120	13.8
175	18	5	8	4	200	16.4
200	23	8	8	3	180	20.3
250	23	8	8	3	380	24.6
300	23	8	8	3	400	29.2
350	23	8	8	2.5	800	44.3
400	23	8	8	2.5	900	54.0
450	25	15	15	4.0	1500	70.3
500	25	15	15	3.5	1800	79.4

Please inquire for simultaneous (different) movement
*Effective bellows cross sectional area is a theoretical value

Note

Please comply with the general technical instructions regarding reaction force, moving force, fixed point load, installation instructions etc.

Subject to technical alterations and deviations resulting from the manufacturing process.