

Steel pipe connector - Type SR-1 and SR-2

Oscillation and noise damper DN 32 – DN 200

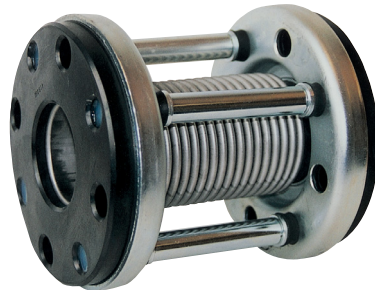

Type SR-1



Type SR-2

Structure type SR-1

- Vacuum-proof axial pipe connector consisting of a stainless steel bellows with oscillation and noise damping rubber elements

Structure type SR-2

- Vacuum-proof lateral pipe connector
- Design as type SR-1, also with tie rods/length limiters, carried elastically on silencing rubber
- Length limiters cannot fully absorb reaction force; sufficiently dimensioned fixed points are necessary

Steel bellows PN 10

Stainless steel bellows with flared ends of material 1.4541

Material grade*	Material No. as per DIN EN	Possible uses
Stainless steel	1.4541	Hot water, acids, lyes

Property	Pressure	Temperature
Max. perm. operating pressure	10 bar 6 bar	up to +100 °C up to +120 °C up to +130 °C for brief periods*

* > +120 °C the manufacturer's approval must be obtained for the corresponding operating conditions.

Flanges

Version

- Self-sealing, oscillation-, and noise-damping flanges
- Rubber elements encapsulated by sheet metal flanges
- Flared ends of steel bellows entirely embedded in rubber elements
- No metallic contact between steel bellows and mating flanges
- Flange drilling for through bolts

Dimensions

Standard: DN 32 - DN 150 (PN 16),
DN 200 (PN 10)
according to EN 1092

Connection dimensions see technical annex

Materials

Standard: 1.0038 (S235JR) + EPDM

Corrosion protection

Standard: electrogalvanized

Rubber grade**/rubber element	Possible uses
EPDM	Hot water, acids, lyes

**Check or inquire about the resistance of the rubber grade to temperature and medium.

Applications

- for reducing tension and damping oscillation and noise transmission at
 - motors
 - pumps
 - machines
- for installation in
 - industrial applications
 - heating systems
 - distribution station of district heating systems

Certificates

- CE (DGR 97/23/EC)



STENFLEX® type SR-2 at pumps

Dimensions standard program

DN	BL	Pres- sure rate bar	A Effective bellows cross sectional area cm ²	ø Da Bellows outer ø mm	PN Flange connec- tion EN 1092	ø D Flange outer ø mm	b Flange thick- ness mm	Screws			Washer DIN 125	Weight type SR-1 approx. kg	Weight type SR-2 approx. kg
								Thread	L mm	L ₁ mm			
32	152	10	16	54	16	140	32	M 16	75	90	17	1.7	1.8
40	155	10	25	66	16	150	35	M 16	75	90	17	2.3	2.4
50	178	10	35	78	16	165	35	M 16	80	90	17	2.9	3.0
65	185	10	55	96	16*	185	38	M 16	80	90	17	4.2	4.3
80	190	10	79	115	16	200	38	M 16	90	100	17	4.4	4.6
100	195	10	115	137	16	220	40	M 16	90	100	17	5.8	6.0
125	215	10	175	168	16	250	42	M 16	90	100	17	7.8	8.2
150	250	10	245	196	16	285	44	M 20	90	100	21	9.8	10.3
200	250	10	423	253	10	340	44	M 20	90	100	21	14.5	15.0

*With 4 flange borings.

Versions

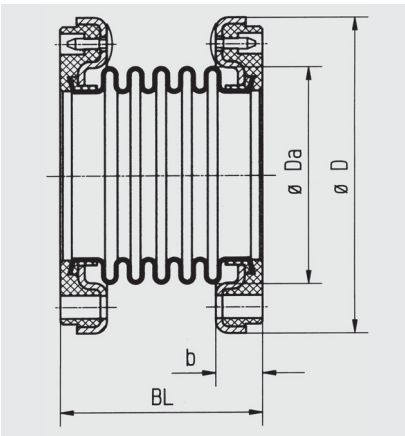

Type SR-1
Steel pipe connector

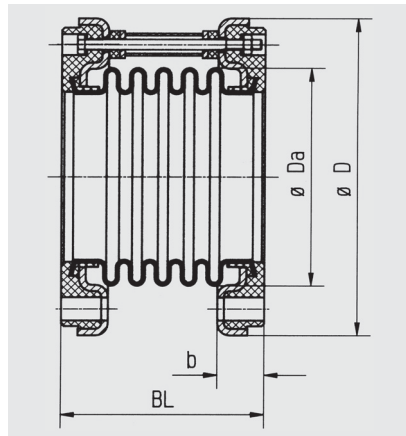

Type SR-2
Steel pipe connector with tie
rods/length limiters, carried elastically
on silencing rubber

Screw lengths

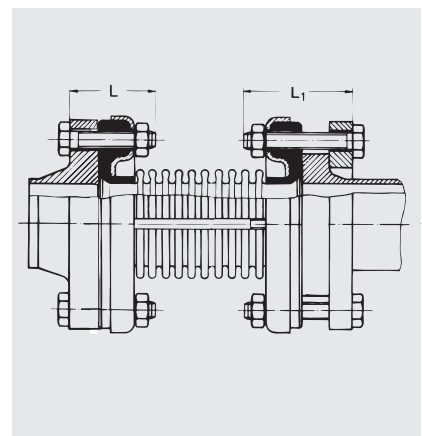

Recommended screw length L and L₁

Note

Please note the recommended screw length L and L₁ (see table).

Please comply with the general technical instructions.

Subject to technical alterations and deviations resulting from the manufacturing process.

Detailed installation instructions indicating the necessary torques are included with every pipe connector.

Chemicals used for water treatment (particularly in heating systems and coolant systems) can corrode the materials of pipe connector. According to VDI Directive 2035, DIN 4809 part 1 and VGB R 455P, the manufacturer of the chemicals must state that the materials used in the pipe connector will not be damaged by the chemicals.